



Reliability In Action

L958H WHEEL LOADER

Operating weight: 18000 kg

Bucket capacity: 3.5 (2.7~5.0) m³

Engine power: 162 kW



High-efficiency

Reliability

Energy-saving

Comfort

L958H

Main Specifications

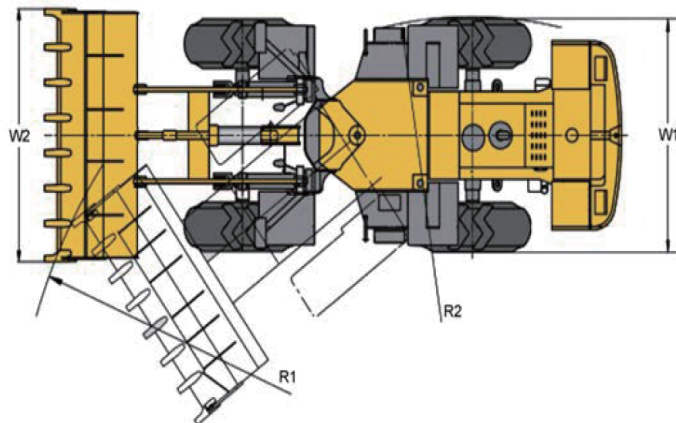
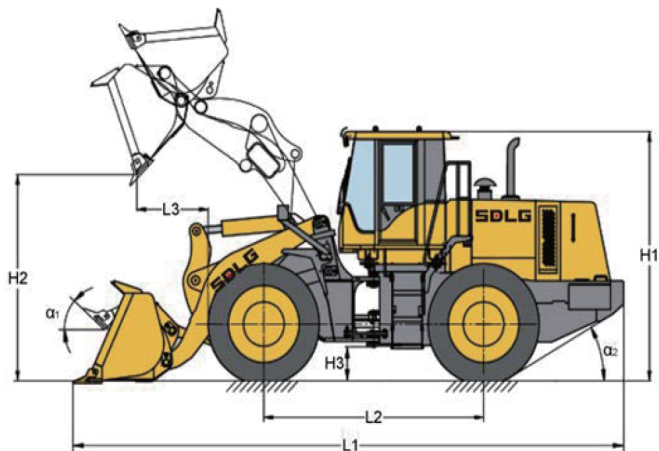

Overall parameter

Operating weight (kg)	18000
Rated load (kg)	5800
Bucket capacity (m³)	3.5
Max. tractive force (kN)	160
Max. breakout force (kN)	≥180

Transmission system

Transmission type	Countershaft Electro-hydraulic Shifting
Gears	Forward 4 & Reverse 4
Forward speed (km/h)	7/12.5/27/38
Reverse speed (km/h)	7/12.5/27/38

Hydraulic system of working device

Working device hydraulic system pressure (MPa)	19.5
Total cycle time (bucket lift & dump & fall)(s)	≤10.6

Steering system

Steering system pressure (Mpa)	16
--------------------------------	----

Engine

Engine power (kW)	162
Rated speed (r/min)	2200 r/min
Emission standard	Brazil T3

Overall dimension

Overall length L1 (mm)	8370
Outside width of wheel W1 (mm)	2785
Bucket width W2 (mm)	3024
Overall height H1 (mm)	3450
Wheel base L2 (mm)	3400 (1700+1700)
Minimum ground clearance H3 (mm)	420
Maximum unloading height H2 (mm)	3110
Corresponding unloading distance L3 (mm)	1190
Horizontal clearance radius R1 (outside of bucket)(mm)	7030
Minimum turning radius R2 (outside of rear wheel)(mm)	6030
Dumping angle	-45°
Steering angle	38°

Service capacities

Fuel (L)	300
Hydraulic oil (L)	240
Engine oil (L)	20
Transmission oil (L)	17.1/4.7
Axle (front/rear)(L)	46+46
Antifreeze coolant (L)	55

STD Configuration

BFM8-22T3R/6 Engine
SDLG VRTE205 Transmission & SDLG Dry/Wet Axle
Pilot Control, 3-spool Valve
Load-Sensing Full Hydraulic Steering
ROPS Cab (with A.C, Radio)
Wheel: 23.5-25-18PR-L3(front),23.5-25-16PR-L3(rear)
Starting Interlock
Tachometer/Radio/Adjustable Steering Column/Rotating Beacon
GP Bucket 3.5m³

* SDLG reserves the right to change specifications and materials at any time without prior notification. Features of the machine in photos may include additional equipment. If you need more information and available options, please contact your local distributor or SDLG.



Shandong Lingong Construction Machinery Co., Ltd.

Add: Lingong Industry Park, Economic Development Zone, Linyi, Shandong, P.R.China

Tel: 0086-531-66590505 Fax: 0086-531-66590505 E-mail: export@sdlg.com Website: www.sdlg.com