



**Reliability In Action**

# **E6505H**

## **HYDRAULIC EXCAVATOR**

**Operating weight: 52000 kg**

**Bucket capacity: 3.2 m<sup>3</sup>**

**Engine power: 340 kW**



**Powerful And High Efficient**

**Reliable And Stable**

**Safe And Comfort**

# E6505H

## Main specifications

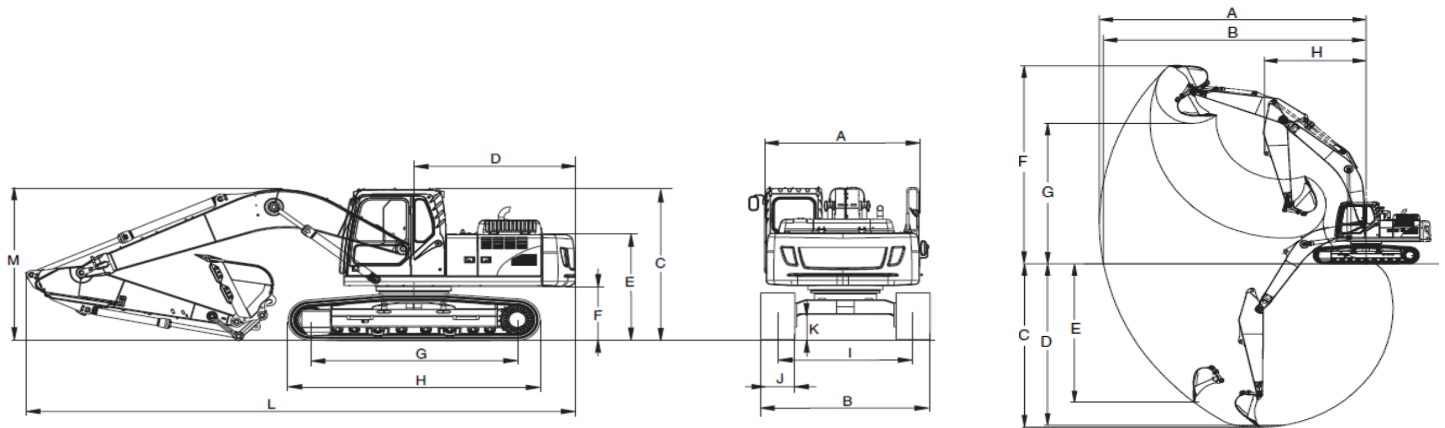

### Specifications

Operating weight(kg)	52000
Bucket capacity(m <sup>3</sup> )	3.2
Boom length(mm)	6500
Arm length(mm)	3000

### Engine

Engine Model	X12 S3A375
Engine Type	Four-stroke,turbocharged,inter-cooled
Emission	Stage IIIA
Engine power(kW)	340
Rated engine speed(r/min)	2100
Maximum torque(N.m)/rotation speed(r/min)	1898/1400
Displacement(ml)	11800

### Main performance

Traveling speed (low/high) (km/h)	3.2/5.3
Slewing speed (r/min)	8.5
Average ground pressure (kPa)	88.7
Bucket Digging Force (ISO) (kN)	276.5

### Travelling section

Number of track shoes	50
Number of carrier roller (one side)	2
Number of supporting wheel (one side)	9
Track shoe width (mm)	600

### Service capacity

Fuel tank(L)	760
Hydraulic oil tank(L)	235
Engine oil(L)	43
Hydraulic system(L)	550
Cooling system(L)	70

### Overall specifications

Unit: mm

A	Overall width of upper assembly	3235
B	Overall width	3565
C	Overall height of cab	-
D	Tail swing radius	4025
E	Overall height of engine hood	-
F	Counterweight clearance	1300
G	Wheel base	4420
H	Track length	5480
I	Track gauge	2740
J	Track width	600
K	Min. ground clearance	527
L	Overall length	11850
M	Overall height of boom	3757

### Overall range

Unit: mm

A	Max. digging reach	11290
B	Max. digging reach on ground	11050
C	Max. digging depth	7030
D	Max. digging depth (horizontal 2.44 m)	6910
E	Max. vertical wall digging depth	-
F	Max. cutting height	10590
G	Max. dumping height	7020
H	Min. front swing radius	4740

\*SDLG reserves the right to change specifications and materials at any time without prior notification. Features of the machine in photos may include additional equipment.If you need more information and available options, please contact your local distributor or SDLG.



**Shandong Lingong Construction Machinery Co., Ltd.**

Add: Lingong Industry Park, Economic Development Zone, Linyi, Shandong, P.R.China

Tel: 0086-531-66590505 Fax: 0086-531-66590505 E-mail: export@sdlg.com Website: www.sdlg.com