



Reliability In Action

B876FH

BACKHOE LOADER

Engine Power: 70 kW

Maximum Speed: 38 km/h

Standard Loader Bucket Capacity: 1.0 m³

Standard Backhoe Bucket Capacity: 0.18 m³

Operating Weight: 7800 kg



Energy-saving

Reliable

Comfortable

Convenient

B876FH

Main specifications

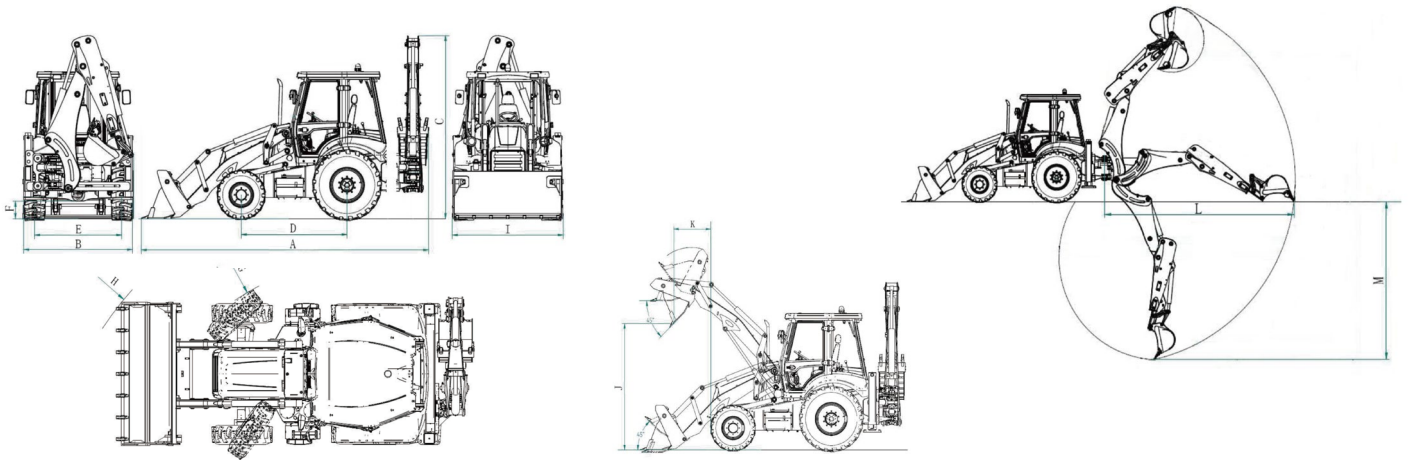

Machine Parameters	
Operating Weight(kg)	7800
Rated load(kg)	1800
Standard Loader Bucket Capacity(m ³)	1.0
Standard Backhoe Bucket Capacity(m ³)	0.18
Maximum Traction Force(kN)	82
Maximum Breakout Force(kN)	50
Maximum Digging Force(kN)	58
Engine	YC4A105Z-T20
Engine Type	In-line, water-cooled, four-stroke, supercharged
Engine Power(kW)	70
Roted Engine Speed(r/min)	2200
Maximum Torque/Engine Speed(N.m/(r/min))	420/1500~1600
Displacement(ml)	GB 20891-2007(stage II)
Gear	F4R4
1st Maximum Speed, fwd/rev(km/h)	6
2nd Maximum Speed, fwd/rev(km/h)	10
3rd Maximum Speed, fwd/rev(km/h)	20
4th Maximum Speed, fwd/rev(km/h)	38
Service Brake Type	Hydraulic power assist
Parking Brake Type	Caliper disc
Tire Size	12.5/80-18/18.4-26
Loading Operation Type	Parallel 8-link mechanism

Loading Working Pressure(kPa)	23.5
Cycle time(s)	9.1
Digging Operation Type	Standard Arm
Digging Working Pressure (Digging/Steering)(kPa)	23.5/15
Steering System Type	Load sensing
Fuel(L)	135
Hydraulic Oil(L)	165
Transmission Oil(L)	20
Axle(L)	Front:7.5+0.8*2,Rear:15
Engine Oil(L)	11
Overall dimension Unit: mm	
A Overall Length	7243
B Width Of Wheel	2265
C Overall Height	3608
D Wheelbase	2170
E Track Width	-
F Minimum Ground Clearance	346
G Turning Radius Outside of Front Tire	4118
H Turning Radius Outside of Bucket	5350
I Width Of Loader Bucket	2350
J Maximum Dumping Height	2693
K Corresponding Dump Distance	830
L Maximum Digging Reach	5393

M Maximum Digging Depth	4303
STD Configuration	
Yuchai YC4A105Z	
CARRARO Transmission	
CARRARO Axle	
Pilot Control	
Mail Control Valve2-Way Valve(loading); 7-Way Valve(excavating)	
Tire(Front/Rear):12.5/80-18/18.4-26	
Rops Cab with AC	
License Plate Bracket	
Front Mudguard	
Reverse Buzzer	
Rotating Beacon	
Air pre-filter	
STD Loading Bucket 1.0m ³	
Standard Backhoe Bucket 0.18m ³	
Options	
STD bucket:0.08 0.11 0.13 0.23 0.3m ³ (loading)	
Levelling bucket 0.21m ³ (excavating)	
Hammer φ68	
Rearview mirror	
Wear-resistant plate for loading end bucket	
Mechanical quick coupler for excavating end	

*SDLG reserves the right to change specifications and materials at any time without prior notification. Features of the machine in photos may include additional equipment.If you need more information and available options, please contact your local distributor or SDLG.



Shandong Lingong Construction Machinery Co., Ltd.

Add: Lingong Industry Park, Economic Development Zone, Linyi, Shandong, P. R. China

Tel: + 86-531-66590505 Fax: + 86-531-66590505 E-mail: export@sdlg.com Website: www.sdlg.com