



Reliability In Action

RS8220H

SINGLE DRUM ROLLER

Engine Power: 140 kW

Nominal Amplitude Range: 2.0/1.0 mm

Vibration Frequency Range: 28/33 Hz



**Powerful Engine,
High Compaction Efficiency**

**High-End Design,
Reliable & Durable**

**Comfortable & Safe,
Easy Maintenance**

RS8220H

Main specifications

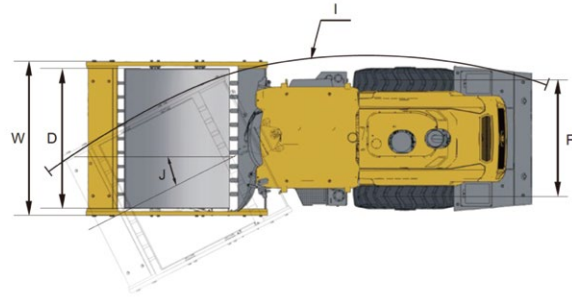
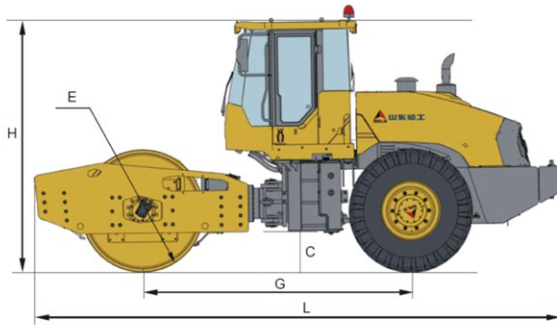

Item	Parameter	Item	Parameter	Item	Parameter
Overall dimension		Min. Fuel-consume ratio (g/kw.h)	≤212	Drive axle main drive and wheel reducer (L)	16+2×5
L×W×H (mm)	6851×2353×3180	Max. torque (N.m/rpm)	900/(1300-1500)	Brake system (L)	2
Width of vibratory drum (D) (mm)	2150	Transmission system		STD Configuration	
Wheel tread (F) (mm)	1610	Clutch type	Single Dry Plate Clutch	Weichai WP6G190E301	
Wheelbase (G) (mm)	3507	Transmission type	Mechanical Shift Transmission	Mechanical Shift Transmission	
Min ground clearance (C) (mm)	400	Gears	F3R2	Special Drive Axle for SDLG Roller	
Min turning radius (I) (mm)	6600	Speed at forward/reverse gear I (km/h)	0-2.6	Closed Circuit Vibration System	
Theoretical gradeability	30%	Speed at forward/reverse gear II (km/h)	0-5.0	Rear Wheel Mechanical Drive	
Turning angle (J) (°)	±35	Speed at forward gear III (km/h)	0-10.5	Single Drum Smooth Wheel Vibratory Roller	
Overall performance		Brake system		STD Cab	
Operating weight (kg)	22000	Service brake type	Air-over-Hydraulic Caliper Disc Brake	Air Conditioner	
Wheel distributed weight (front/rear) (kg)	11000/11000	Parking brake type	Manual Drum Brake	Water-Filled Tire	
Nominal amplitude (high/low) (mm)	2.0/1.0	Steering system		Rotating Beacon	
Vibration frequency (Hz)	28/33	Steering system type	Open Circuit System	Options	
Excitation force (high/low) (kN)	402/280	System pressure (MPa)	14	Seat Module (with Safety Belt)	
Static linear load (N/cm)	511	Swing angle (°)	±12	Transmission + Propeller Shaft Assembly	
Engine		Vibratory system		Padfoot Shell Assembly (1600mm)	
Engine model	WP6G190E301	Vibratory system type	Closed Circuit System		
Engine type	In-line, Water-cooled, Four-stroke, Direct Injection	Service capacities			
Rated Power/Speed (kW/rpm)	140/2000	Fuel capacity (L)	270		
Engine displacement (ml)	6750	Hydraulic oil (L)	60		
Cylinder bore/stroke (mm)	105/130	Engine oil (L)	16		
Emission standard	GB 20891-2014(stage III)	Transmission (L)	9+6		

* SDLG constantly improves its products, and the configuration parameters will be continuously updated. We reserve the right to change the design and parameters without prior notice to users. The product configuration and appearance are subject to the physical object.



Shandong Lingong Construction Machinery Co., Ltd.

Add: Lingong Industry Park, Economic Development Zone, Linyi, Shandong, P. R. China

Tel: + 86-531-66590505 Fax: + 86-531-66590505 E-mail: export@sdlg.com Website: www.sdlg.com