



Reliability In Action

E6395H

HYDRAULIC EXCAVATOR

Operating weight: 39300 kg

Bucket capacity: 1.9 m³

Engine power: 212 kW



Better adaptability & energy efficient

Reliable & durable

Comfortable & convenient

E6395H

Main specifications

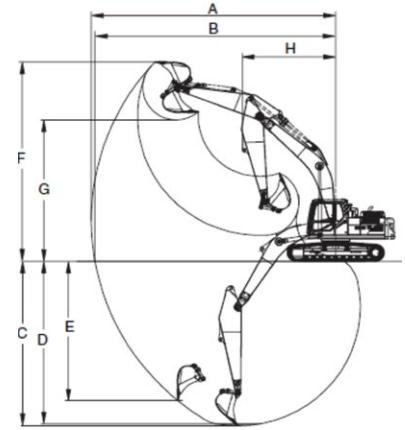
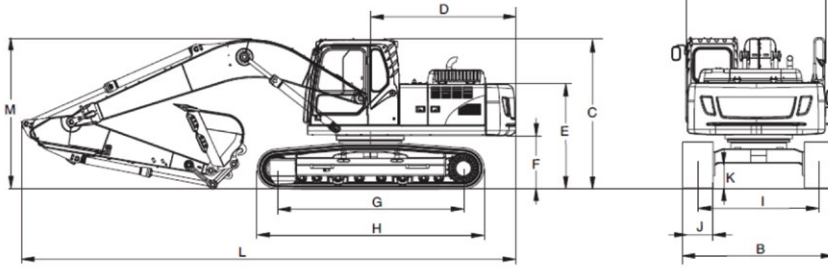

Specifications

Operating weight(kg)	39300
Bucket capacity(m ³)	1.9
Boom length(mm)	6450
Arm length(mm)	2950

Engine

Engine Model	6HK1XWSC-02
Engine Type	In-Line, Six-Cylinder, Turbocharged, intercooled
Emission	GB 20891-2007(China Stage II)
Engine power(kW)	212
Rated engine speed(r/min)	2000
Maximum torque (N.m)/rotation speed (r/min)	1080/1500
Displacement(ml)	7790

Main performance

Traveling speed (low/high) (km/h)	3.4/5.1
Slewing speed (r/min)	9.1
Average ground pressure (kPa)	71.7
Bucket Digging Force (ISO) (kN)	241

Travelling section

Number of carrier roller (one side)	2
Number of supporting wheel (one side)	9

Service capacity

Fuel tank(L)	725
Hydraulic oil tank(L)	195
Engine oil(L)	38
Hydraulic system(L)	455
Cooling system(L)	45

Overall specifications

	Unit: mm
A Overall width of upper assembly	3560
B Overall width	3570
C Overall height of cab	-
D Tail swing radius	3649
E Overall height of engine hood	-
F Counterweight clearance	1210
G Wheel base	4240
H Track length	5180
I Track gauge	2740
J Track width	600
K Min. ground clearance	556
L Overall length	11370
M Overall height of boom	-

Overall range

	Unit: mm
A Max. digging reach	11010
B Max. digging reach on ground	10800
C Max. digging depth	7270
D Max. digging depth (horizontal 2.44 m)	7100
E Max. vertical wall digging depth	5670
F Max. cutting height	10220
G Max. dumping height	7170
H Min. front swing radius	4400

Standard configuration

ISUZU 6HK1 Engine
STD Boom 6450mm & Arm 2950mm
Full Electrically Controlled Hydraulic System
Hydraulic Drive
Rops CAB
Hammer Pipeline
Rotating Beacon
Rock Bucket 1.9m ³ ×1580 (LC550RC Bucket Teeth)

Optional equipment

Rock Bucket 1.8m ³ (LC450RC Bucket Teeth)
Rock Bucket 1.8m ³ (LC550TL Bucket Teeth)
Rock Bucket 1.9m ³ ×1720 (LC550RC Bucket Teeth)
GP Bucket 1.9/2.0m ³ (LC450TL Bucket Teeth)
GP Bucket 2.0m ³ (LC450RC Bucket Teeth)
Oil-bath Air Filter
Fuel Adding Pump
Diamond Bucket Tooth Module(LC450RC/LC550RC)
Front Cab Guards For Light-duty/Heavy-duty
Cab Roof Guard For Heavy-duty
Boom Working Lights (4LEDS)
Hydraulic Oil Module For High-Temperature Environment
Track Shoe (700/800/900 mm)
GPS/Tbox (Select according to country)

*SDLG reserves the right to change specifications and materials at any time without prior notification. Features of the machine in photos may include additional equipment. If you need more information and available options, please contact your local distributor or SDLG.



Shandong Lingong Construction Machinery Co., Ltd.

Add: Lingong Industry Park, Economic Development Zone, Linyi, Shandong, P. R. China
Tel: 0086-531-66590505 Fax: 0086-531-66590505 E-mail: export@sdlg.com