



Reliability In Action

E6350H

Hydraulic Excavator

Operating weight: 35200kg

Bucket capacity: 2.0 m³

Engine power: 215 kW



Powerful And Adaptable

215kW high-power engine with excellent fuel adaptability.

Premium And Reliable

Equipped with full electronic control positive flow hydraulic system, enlarged radiator, reinforced large chassis, heavy-duty structural components & frame, and three-stage fuel filtration system.

Safety And Comfort

The H-Series ROPS Cab comes standard with a comprehensive safety protection system, ergonomic air suspension seat with seat heating function, an intuitive touchscreen IECU.

E6350H

Main specifications

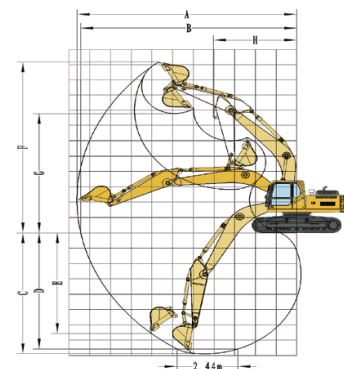
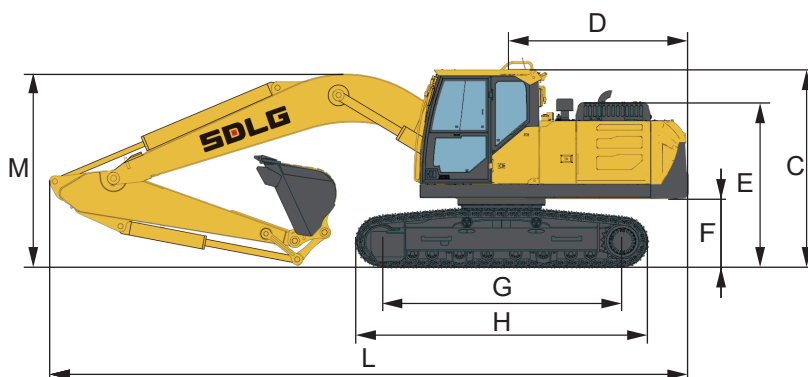
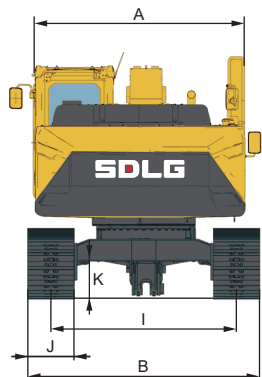

Specifications

Operating weight(kg)	35200
Bucket capacity(m ³)	2.0
Boom length(mm)	6200
Arm length(mm)	2600

Engine

Engine Model	BFM8-29T2
Engine Type	Four-stroke, Turbocharged, Inter-cooled
Emission	GB 20891-2007 Stage II
Engine power(kW)	215
Rated engine speed(r/min)	1800
Maximum torque (N.m)/rotation speed (r/min)	1255/1350
Displacement(ml)	7800

Main performance

Traveling speed (low/high)(km/h)	3.0/5.0
Slewing speed (r/min)	10.7
Gradeability (°)	35
Average ground pressure (kPa)	63.6
Bucket Digging Force (ISO)(kN)	238
Arm Digging Force (ISO)(kN)	219
Max. drawbar pull(kN)	-

Travelling section

Number of track shoes(one side)	49
Number of carrier roller (one side)	2
Number of supporting wheel (one side)	9
Track shoe width (mm)	600

Overall specifications

	Unit: mm
A Overall width of upper assembly	2950
B Overall width	3190
C Overall height of cab	3150
D Tail swing radius	3530
E Overall height of engine hood	2885
F Counterweight clearance	1215
G Wheel base	4130
H Track length	5070
I Track gauge	2590
J Track width	600
K Min. ground clearance	520
L Overall length	11000
M Overall height of boom	3600

Overall range

	Unit: mm
A Max. digging reach	10360
B Max. digging reach on ground	10140
C Max. digging depth	6680
D Max. digging depth (horizontal 2.44m)	6465
E Max. vertical wall digging depth	5050
F Max. cutting height	9900
G Max. dumping height	6840
H Min. front swing radius	4085

Service capacity

Fuel tank(L)	590
Hydraulic oil tank(L)	195
Engine oil(L)	28
Hydraulic system(L)	480
Cooling system(L)	44

Standard configuration

BFM8 Engine
Standard Arm
Fully Electronic Control
Hydraulic Drive
ROPS Cab (with air conditioner)
Bucket 2.0m ³ ×1670

Optional equipment

Standard Bucket 1.7m ³ ×1540 (General Earthmoving)
Bucket 1.7m ³ ×1590 (Slag,Clay etc)
Rock Bucket 1.65m ³ ×1510(Heavy-Duty)
Rock Bucket 1.8m ³ ×1590(Mining)
Diamond RC Bucket Teeth
Hammer Pipeline
Fuel Pump
Rotating Warning Beacon
Heavy Duty Front Protective Net for CAB-FOG-E
Heavy Duty Top Protective Net for CAB
GPS Certification Mark For Indonesia
Travelling Alarm



Shandong Lingong Construction Machinery Co., Ltd.

Add: Lingong Industry Park, Economic Development Zone, Linyi, Shandong, P. R. China

Tel: + 86-531-66590505 Fax: + 86-531-66590505 E-mail: export@sdlg.com Website: www.sdlg.com