



Reliability In Action

E6210H

Hydraulic Excavator

Operating weight: 21000 kg

Bucket capacity: 1.0 m³

Engine power: 133 kW



Better adaptability & Energy efficient

Reliability & Durability

Comfortable & Convenient

E6210H

Main specifications

Specifications	
Operating weight(kg)	21000
Bucket capacity(m³)	1.0
Boom length(mm)	5700
Arm length(mm)	2900
Service capacity	
Fuel tank(L)	390
Hydraulic oil tank(L)	110
Engine oil(L)	26.5
Hydraulic system(L)	230
Cooling system(L)	32
Travelling section	
Number of carrier roller (one side)	2
Number of supporting wheel (one side)	7
Engine	
Engine Model	6BTAA5.9
Engine Type	In-Line, Six-Cylinder, Turbocharged, intercooled, Mechanical Pump
Emission	GB 20891-2007(Stage II)
Engine power(kW)	133
Rated engine speed(r/min)	2000
Maximum torque (N.m)/rotation speed (r/min)	708/1500
Displacement(ml)	5900

Main performance	
Traveling speed (low/high) (km/h)	3.7/5.1
Slewing speed (r/min)	12.1
Average ground pressure (kPa)	44.2
Bucket Digging Force (ISO) (kN)	140.1
Overall specifications	
Unit: mm	
A Overall width of upper assembly	2700
B Overall width	2800
C Overall height of cab	2940
D Tail swing radius	2880
E Overall height of engine hood	2510
F Counterweight clearance	1032
G Wheel base	3370
H Track length	4170
I Track gauge	2200
J Track width	600
K Min. ground clearance	460
L Overall length	9720
M Overall height of boom	2940
Overall range	
Unit: mm	
A Max. digging reach	9940
B Max. digging reach on ground	9750
C Max. digging depth	6730
D Max. digging depth (horizontal 2.44 m)	6510
E Max. vertical wall digging depth	5830
F Max. cutting height	9450
G Max. dumping height	6650
H Min. front swing radius	3650
Standard Configuration	
Cummins 6BTAA5.9	
Boom 5700mm & Arm 2900mm	
Negative Flow Hydraulic System	
KPM Main Pump	
Three-stage Fuel Filtration	
Rops CAB(with Air conditioner)	
8 inch LCD touch screen IECU	
600mm Tracks	
Hammer Pipeline	
GP Bucket 1.0m³	

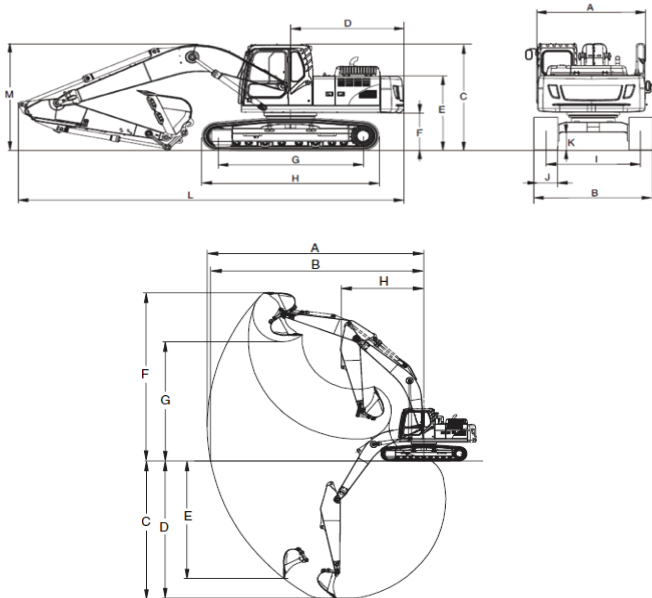

*SDLG reserves the right to change specifications and materials at any time without prior notification. Features of the machine in photos may include additional equipment. If you need more information and available options, please contact your local distributor or SDLG.



Shandong Lingong Construction Machinery Co., Ltd.

Add: Lingong Industry Park, Economic Development Zone, Linyi, Shandong, P. R. China

Tel: + 86-531-66590505 Fax: + 86-531-66590505 E-mail: export@sdlg.com Website: www.sdlg.com