



Reliability In Action

E6505H HYDRAULIC EXCAVATOR

Operating weight: 52000 kg

Bucket capacity: 3.2 m³

Engine power: 321 kW



Powerful And High Efficient

High-power and large-displacement engine with low speed and high torque, a high-pressure common rail injection system, and multiple working modes.

Reliable And Stable

Fully electronically controlled hydraulic system, an independent large hydraulic oil cooler, a large chassis, sturdy structural components and frame, and multiple levels of filtration.

Safe And Comfort

Comfortable cab with safety protection features, an air-suspended seat, a touchscreen IECU, seat heating, centralized lubrication and maintenance layout, and a rear camera.

E6505H

Main specifications

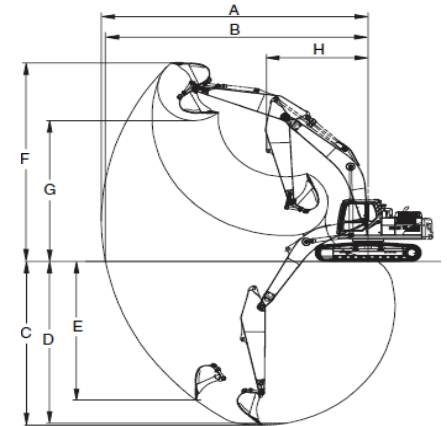
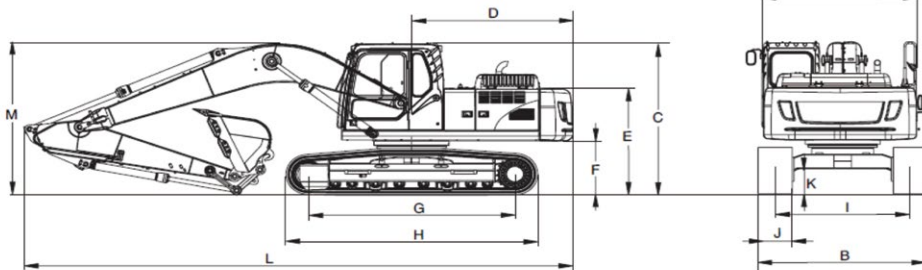

Specifications	
Operating weight(kg)	52000
Bucket capacity(m ³)	3.2
Boom length(mm)	6500
Arm length(mm)	3000
Engine	
Engine Model	X1253A360
Engine Type	Four-stroke,turbocharged,inter-cooled
Emission	Stage IIIA
Engine power(kw)	321
Rated engine speed(r/min)	2100
Maximum torque(N.m)/rotation speed(r/min)	1898/1300
Displacement(ml)	11800
Main performance	
Traveling speed (low/high) (km/h)	3.2/5.3
Slewing speed (r/min)	8.5
Average ground pressure (kPa)	88.7
Bucket Digging Force (ISO) (kN)	276.5
Travelling section	
Number of track shoes	50
Number of carrier roller (one side)	2
Number of supporting wheel (one side)	9
Track shoe width (mm)	600
Service capacity	
Fuel tank(L)	760
Hydraulic oil tank(L)	235
Engine oil(L)	43
Hydraulic system(L)	550
Cooling system(L)	70

Overall specifications		Unit: mm
A	Overall width of upper assembly	3235
B	Overall width	3565
C	Overall height of cab	3380
D	Tail swing radius	4025
E	Overall height of engine hood	2989
F	Counterweight clearance	1300
G	Wheel base	4420
H	Track length	5480
I	Track gauge	2740
J	Track width	600
K	Min. ground clearance	527
L	Overall length	11850
M	Overall height of boom	3757
Overall range		Unit: mm
A	Max. digging reach	11290
B	Max. digging reach on ground	11050
C	Max. digging depth	7030
D	Max. digging depth (horizontal 2.44 m)	6910
E	Max. vertical wall digging depth	5600
F	Max. cutting height	10590
G	Max. dumping height	7020
H	Min. front swing radius	4740

Standard configuration	
Cummins X12	
6.5m Boom & 3.0m Arm	
Fully electric control	
Hydraulic drive	
FOPS cab (with air conditioning)	
Bucket 3.2m ³ ×1960	
Optional equipment	
Bucket 2.8m ³ ×1825 (Heavy duty/Mining)	
Bucket 3.0m ³ ×2018 (Wide and shallow)	
Bucket 3.2m ³ ×1965 (Heavy duty,Iron mine)	
Bucket 3.4m ³ ×2050 (Light duty)	
Hammer Pipeline	
Hammer φ195~200mm	
Fuel Pump	
Oil-bath Air Filter(PSD)	
Self-cleaning Air Filter(PSD)	
Heavy Duty Front Protective Net for CAB	
Heavy Duty Top Protective Net for CAB	
Waterproof Type Swing Part And Lower Frame	
700/800/900mm Track Shoe With Double Grousers	
600/700/800mm Track Shoe With Triple Grousers	

*SDLG reserves the right to change specifications and materials at any time without prior notification. Features of the machine in photos may include additional equipment.If you need more information and available options, please contact your local distributor or SDLG.



Shandong Lingong Construction Machinery Co., Ltd.

Add: Lingong Industry Park, Economic Development Zone, Linyi, Shandong, P. R.China

Tel: 0086-531-66590505 Fax: 0086-531-66590505 E-mail: export@sdlg.com