



# TV1100H

**SDLG Compact Track Loader**  
**4.55 t (10,031lb) | 53.7kW (72 hp)**

## ● Highlights

- The TV1100H is equipped with a highly reliable Yanmar engine providing 72 horsepower for optimal working performance
- Within the one-piece sealed cab you will find an air suspension seat that includes heat and ventilation, keyless start, and integrated keypads, this unit also provides a full-color 7-inch touch screen with an integrated rearview camera, Radio, Bluetooth, and hand-free phone providing a luxury experience.
- Two-speed travel, ISO and H quick change button, reversing fan, and cruise control are all standard features.
- This unit has High flow is a standard feature, it also offers the operator the ability to immediately adjust the pressure and flow on the 7-inch touchscreen to accommodate a wide range of attachments.
- Daily maintenance service points can be easily achieved through the tilt-up cab and rear door.



**Reliability In Action**

# Specifications

Standard bucket capacity	m <sup>3</sup> (yd <sup>3</sup> )	0.45 (0.59)
Rated operating capacity-35% tipping load	Kg (lbs)	1,180 (2,601)
Operating weight	kg (lbs)	4,550 (10,031)
Engine model	-	Yanmar 4TNV98CT
Rated power	kW (hp)	53.7 (72)
Rated engine speed	rpm	2,500
Displacement	ml (in <sup>3</sup> )	3,300 (201.4)
Low speed	km/h (mi/h)	9 (5.6)
High speed	km/h (mi/h)	13.7 (8.5)
Breakout force	kN (lbf)	30 (6,744)
Standard flow rate	L/min (gal/min)	75 (19.8)
High flow rate	L/min (gal/min)	113 (29.9)
Main relief set pressure	bar (psi)	245 (3,553)
Track Width	mm (in)	400 (15.7)
Ground pressure	kPa (psi)	33 (4.8)
Fuel tank	L (gal)	95 (25.1)

# Dimensions

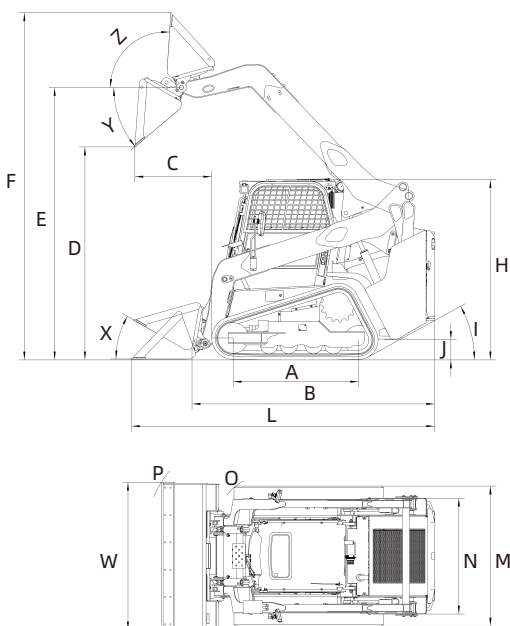

A Length of track on ground	mm (ft in)	1,435(4'8.5")
B Length without bucket	mm (ft in)	2,770(9'1.1")
C Reach at max. lift and dump	mm (ft in)	880(2'10.6")
D Dump height at max. lift	mm (ft in)	2,435(7'11.9")
E Bucket hinge pin height at max. lift	mm (ft in)	3,120(10'2.8")
F Max. overall height	mm (ft in)	3,980(13'0.7")
H Height to top of cab	mm (ft in)	2,065(6'9.3")
I Departure angle	°	29
J Ground clearance	mm (ft in)	225(8.9")
L Overall length	mm (ft in)	3,475(11'4.8")
M Width without bucket	mm (ft in)	1,785(5'10.3")
N Track gauge	mm (ft in)	1,385(4'6.5")
O Turning radius from center- Coupler	mm (ft in)	1,290(4'2.8")
P Turning radius from center- Bucket	mm (ft in)	2,100(6'10.7")
W Bucket width	mm (ft in)	1,880(6'2")
X Bucket rollback angle (ground level)	°	30
Y Max. dump angle	°	40
Z Rack back angle at maximum Height	°	94

\*SDLG reserves the right to change specifications and materials at any time without prior notification. Features of the machine in photos may include additional equipment. If you need more information and available options, please contact your local distributor or SDLG.



Congratulations SDLG for winning EFQM Global Excellence Award, one of the top three quality awards in the world.

## Member of the VOLVO Group since 2006

SDLG is member of the Volvo Group and a leading international manufacturer of construction machinery, and the national-level high-tech company, with a wide network of dealerships and service workshops throughout the world.

## SDLG North America Corp.

Head Office: 14155 West Hardy Road Houston, TX 77060  
 Website: [www.sdlg.com](http://www.sdlg.com) Email: [info@sdlgna.com](mailto:info@sdlgna.com)